

TYPICAL ELEVATION WITH FASTENER SPACING

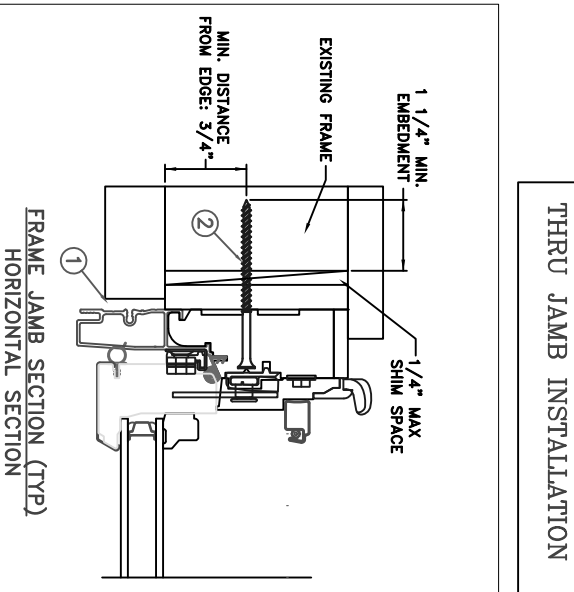
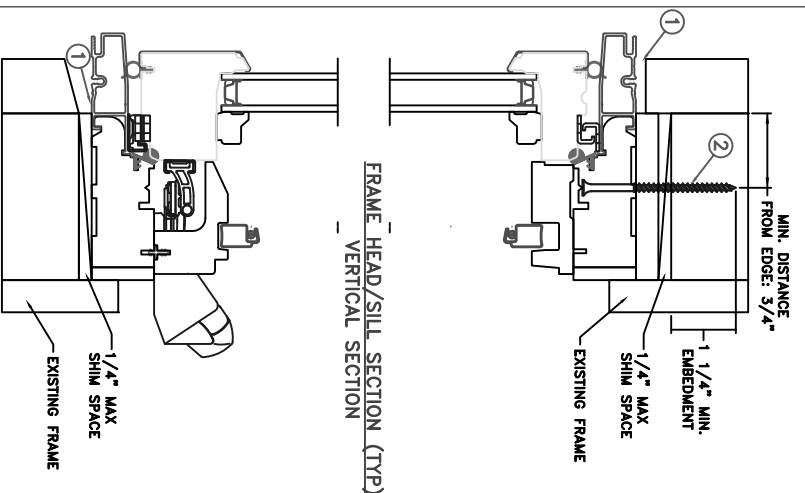

OPERATING POCKET AWNING WINDOW			
Max Frame	DP	IMPACT	
60-7/8 x 48-7/16	+/-35	NO	

Installed Fastener Schedule:

1. Seal flange/frame to substrate.
2. Use #6 PH or greater fasteners through frame with sufficient length to penetrate a minimum of 1 1/4" into the wood framing. For 2X wood frame substrate (min. S.G. = 0.42).

This schedule addresses only the fasteners required to anchor the window to achieve the rated design pressure up to the size limitations noted. It is not intended as a guide to the installation process and does not address the sealing consideration that may arise in different wall conditions. For the complete installation procedure, see the instructions packaged with the window or go to www.jeld-wen.com.

DISCLAIMER:

This drawing and its contents are confidential and are not to be reproduced or copied in whole or in part or used or disclosed to others except as authorized by JELD-WEN Inc.

- General Notes:**
1. The product shown herein is designed, tested and manufactured to comply with the wind load criteria of the adopted International Building Code (IBC), the International Residential Code (IRC), the Florida Building Code (FBC) and the industry standard requirement for the stated conditions.
 2. Buck, framing and masonry by others and its responsibility of architect or engineer of record.
 3. All glazing shall conform to ASTM E1300.
 4. At minimum, glazing shall be double strength annealed insulating glass.

PROJECT ENGINEER: --	DATE: 02/09/2015	PLANT NAME AND LOCATION: Bend, Oregon	
DRAWN BY: D. Vezo	SCALE: NTS	CAD DWG. No.:	REV: 00
CHECKED BY: D. Stokes	TITLE: Custom Clad Pocket Awning Operator	IDENTIFIER No.:	SHEET
APPROVED BY: --			
PART/PROJECT No.:			
D009248			
3737 Lakeport Blvd Klamath Falls, OR. 97601 Phone: (541) 882-3451			